

**VOLVO**  
**164**

cruise  
control

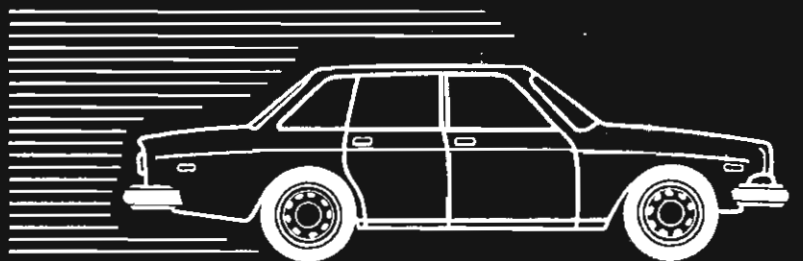

Part # 284056-9

**INSTALLATION INSTRUCTIONS**

Part #284056-9

FOR INSTALLATION ON 1975  
164 SERIES, 6 CYLINDER WITH AUTOMATIC  
TRANSMISSIONS ONLY

## **Volvo of America Corporation**

Rockleigh, N.J. 07647

RETAIN THIS GUIDE IN STUDENT NOTEBOOK FOR FURTHER USE.

The Volvo Cruise Control is a safety related accessory and it is very important that each component be assembled, located, installed carefully and correctly. It is, therefore, suggested that you take a few minutes to familiarize yourself with the parts and the Installation Instructions. The Cruise Control is designed to maintain set vehicle speed within approximately +2, -4 m.p.h. on level roads and moderate grades. When the vehicle is heavily loaded or when negotiating steep grades these tolerances may be temporarily exceeded.

## TABLE OF CONTENTS

	Page
Parts Check List . . . . .	4-5
Installation Instructions . . . . .	6
Operational Check Procedure . . . . .	18
Vehicle Road Check . . . . .	18
Electrical Checks . . . . .	19
Brake Release Check . . . . .	20
Vacuum Check . . . . .	20
Regulator Speed Adjustment . . . . .	20
Circuit Diagram . . . . .	21
Trouble Shooting Guide . . . . .	22-23

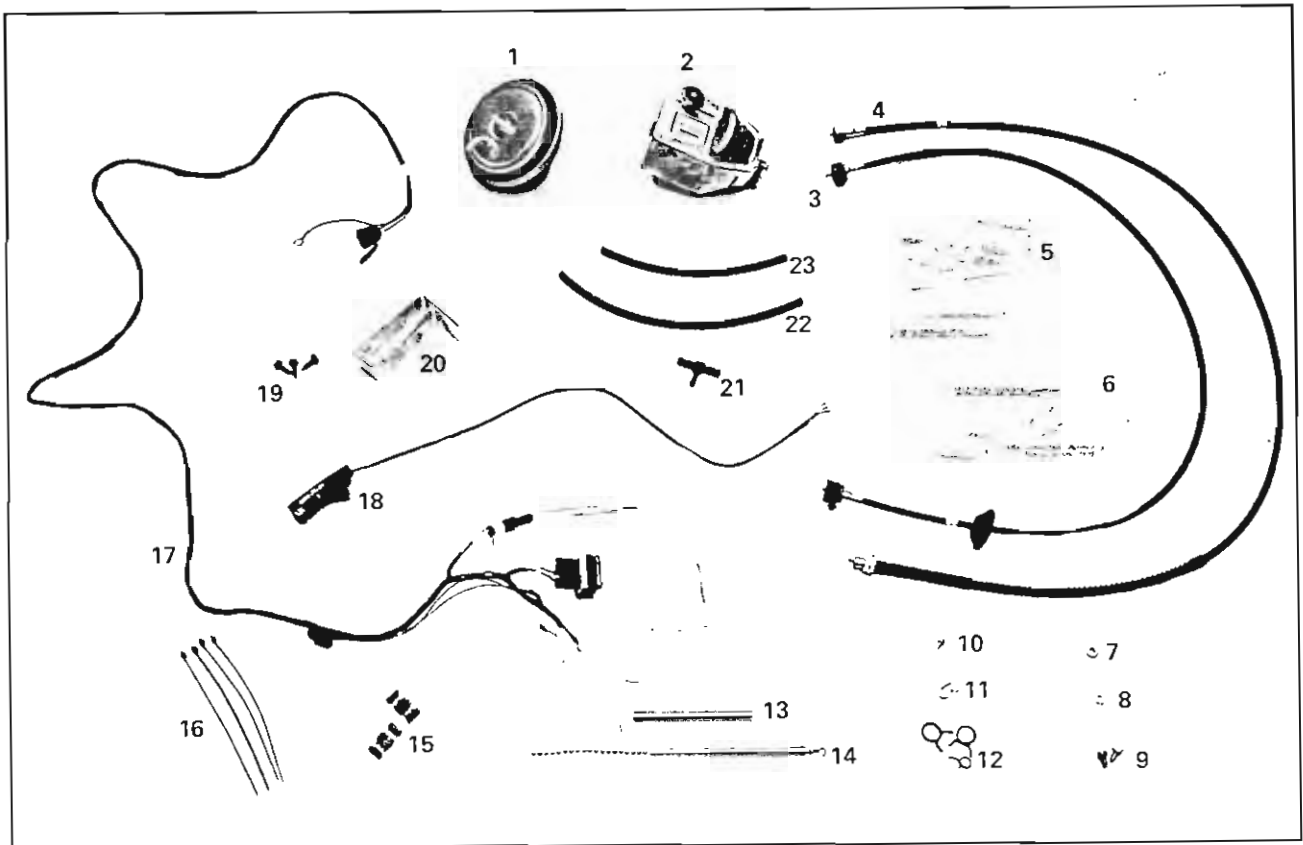

## PARTS CHECK LIST

Place all components in front of you as shown in the illustrated parts list. Replacement parts can be ordered through the Volvo parts system using the part number listed below.

Figure Number	Part Number	Description	Figure Number	Part Number	Description
1	75222-0	Vacuum servo	13	75228-7	Metal chain guide-outer tube with cotter pin.
2	75223-8	Regulator	14	75229-5	Metal chain guide with inner tube attached.
3	75226-1	Speedometer cable	15	Std. Hardware	Self stripping connections
4	75227-9	Transmission cable	16	Std. Hardware	Straps, plastic
5	NSS	Mounting template-servo/regulator bracket.	17	75225-3	Wiring harness
6	NSS	Mounting template-fuel canister.	18	75224-6	Engagement switch assembly
7	Std. Hardware	Nut and lock washer assembly 1/4-20.	19	Std. Hardware	Screws-bracket mounting
8	Std. Hardware	Jam nut 1/4-20.	20	75230-3	Servo/regulator mounting bracket.
9	Std. Hardware	Bolt-regulator mounting	21	75231-1	Vacuum tee
10-11	Std. Hardware	Screw and clamp for transmission cable mounting.	22	Std. Hardware	12" vacuum hose-regulator to tee connection.
12	Std. Hardware	Clamps for vacuum hoses	23	Std. Hardware	9" vacuum hose-regulator to servo connection.

## INSTALLATION INSTRUCTIONS

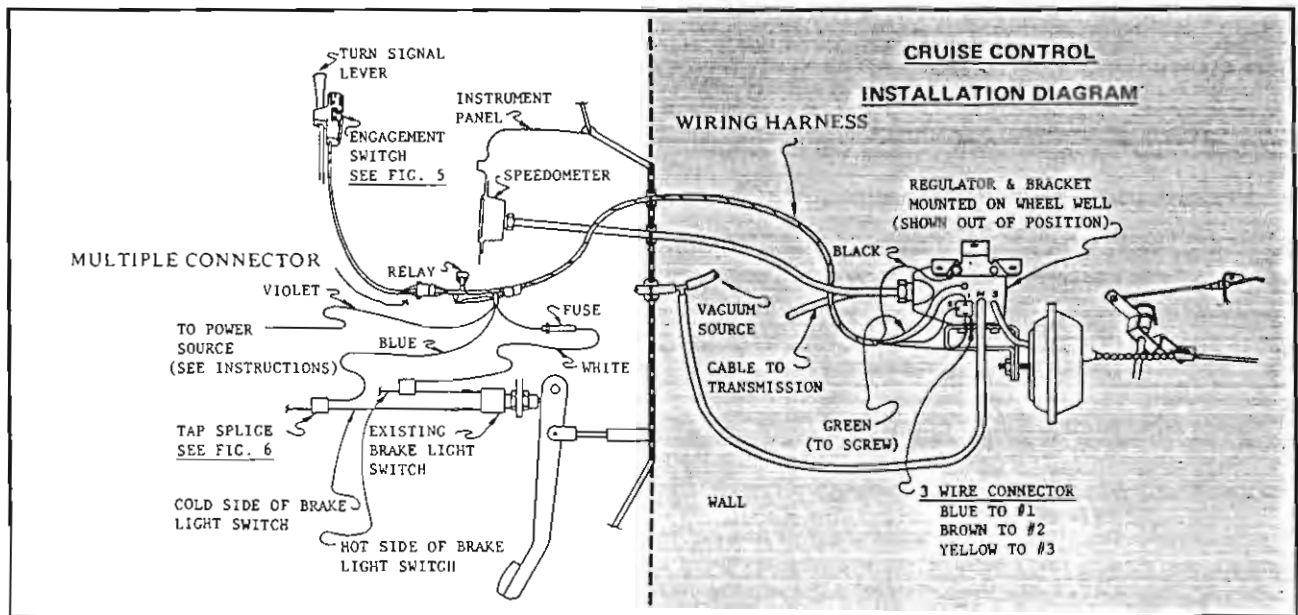

Referring to the installation diagram, note the location of each group of parts. The servo, regulator, and vacuum hose groups are located in the engine compartment. The engagement switch group is clamped on the turn signal lever. The wiring harness and cable group connect the various groups. Since the groups are connected with either cables, electrical leads, or vacuum hoses, it is suggested that the units be positioned in their approximate locations prior to actual mounting.

# INSTALLATION INSTRUCTIONS

The numbers in (parentheses) refer to Speed Control Components Illustrated in the parts picture page 4.

**STEP NO. 1** – Disconnect negative battery cable. Remove air cleaner.

**STEP NO. 2** – Remove fuel canister. Using template (6) provided, drill new 1/4" mounting holes for the fuel canister. Do not reinstall fuel canister at this time.

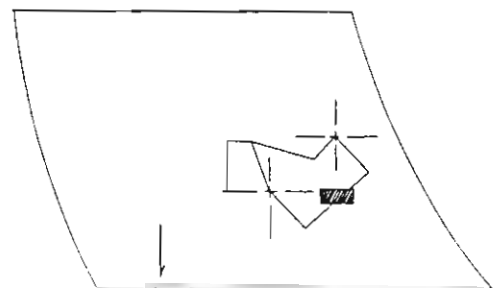

## CABLE CONNECTION

**STEP NO. 3** – Remove panel underneath steering wheel to expose under dash area.

**STEP NO. 4** – Disconnect speedometer cable from speedometer and transmission. Remove cable clamps and firewall grommet. Remove cable from vehicle.

**NOTE:** Oil seal at transmission cable connection. This seal must be in place when new cable is installed.

**STEP NO. 5** – Insert new speedometer cable (3) through firewall and connect plastic nut end to speedometer. Route free end of cable toward regulator area and install grommet supplied on new cable into firewall hole.

**STEP NO. 6** – Route transmission cable (4) from engine compartment to transmission and connect. Reattach all existing cable clamps so that new cable follows original cable routing.

**STEP NO. 7** – Approx. 12 inches forward of the existing transmission cable clamp, drill a 5/32" hole and mount new transmission cable clamp (11) with sheet metal screw (10) provided.

**NOTE:** The purpose of this new clamp is to keep the transmission cable away from the exhaust manifold.

## SERVO MOUNTING

**STEP NO. 8** – Assemble 1/4-20 jam nut (8) to servo stud and run jam nut to bottom of stud. Assemble servo (1) to bracket (20) with 1/4-20 nut and lock (7) washer assembly. Leave jam nut and nut/lock washer loose for later adjustment of bead chain.

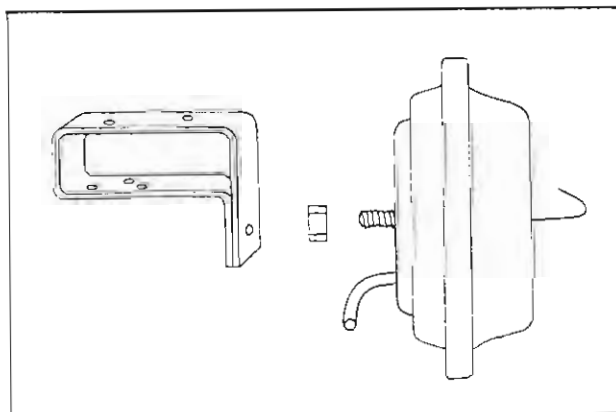

**STEP NO. 9** – Position servo/regulator bracket mounting template (5) in place on right wheel well rib with tape and drill two (2) 11/64" holes. Remove template and attach servo and bracket with three 1/4 x 3/4 (19) washer head tapping screws with short leg of bracket pointing down. Tighten bracket screws securely.

**NOTE:** It will be easier to secure bracket if after drilling you pre-drive screws, and then back them out.

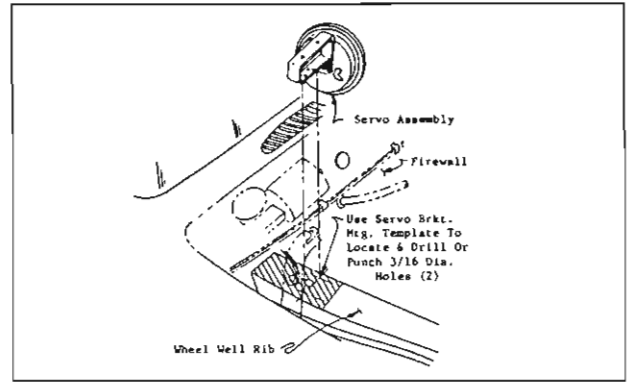

**ATTACHING CHAIN TO SERVO**

**STEP NO. 10** – Remove cotter pin from downshift cable clevis pin. Attach bead chain coupling and chain assembly (14) to downshift cable clevis pin. Replace cotter pin.

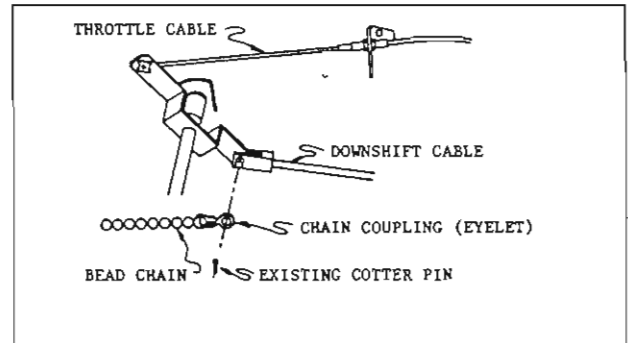

**STEP NO. 11** – Install outer tube (13) of metal chain guide over bead chain. Do not as yet secure to chain with cotter pin.

**NOTE:** It is necessary to install metal chain guide for safety reasons.

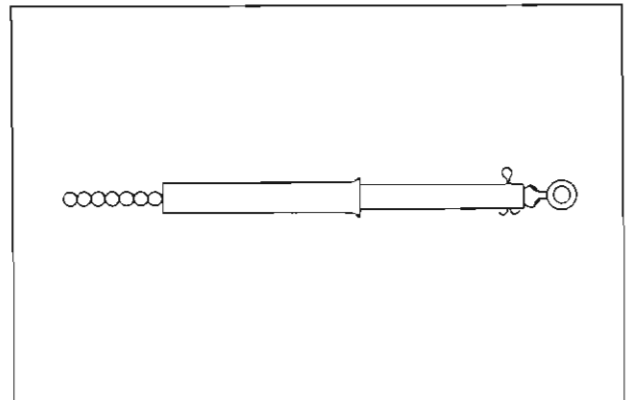

**STEP NO. 12** – Attach bead chain to servo hook and adjust servo jam nut and nut/lock washer to remove slack from bead chain. Tighten jam nut and nut/lock washer assembly.

**CAUTION:** CHAIN MUST NOT BE TIGHT ENOUGH TO AFFECT ENGINE IDLE SPEED.

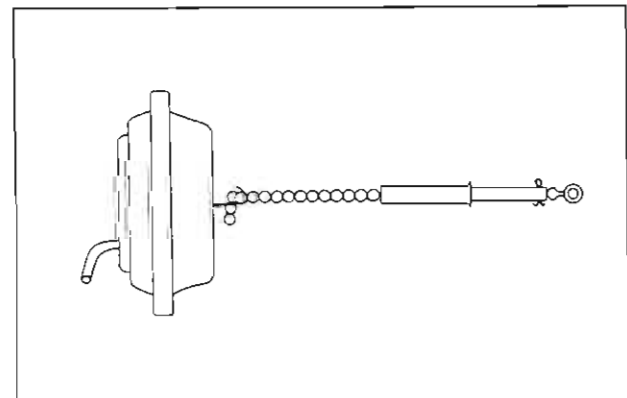

**STEP NO. 13** – Slide metal bead chain guide outer tube as close to servo hook as possible and secure to chain with cotter pin. Crimp servo bead chain hook after installation.

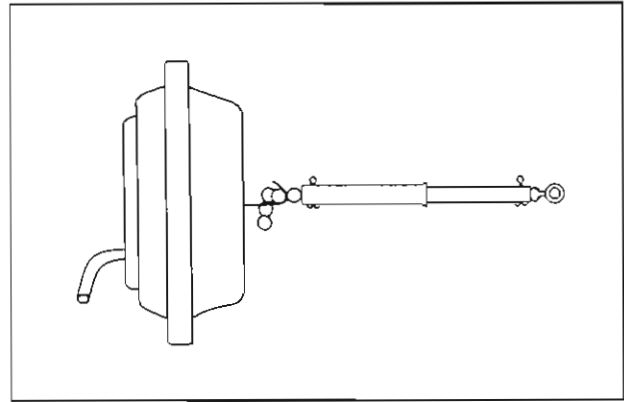

### REGULATOR MOUNTING

**STEP NO. 14** – Assemble regulator (2) to servo/reg mounting bracket using two 1/4-20 x 1/2 hex head bolts (9) *Do not* tighten regulator mounting bolts at this time.

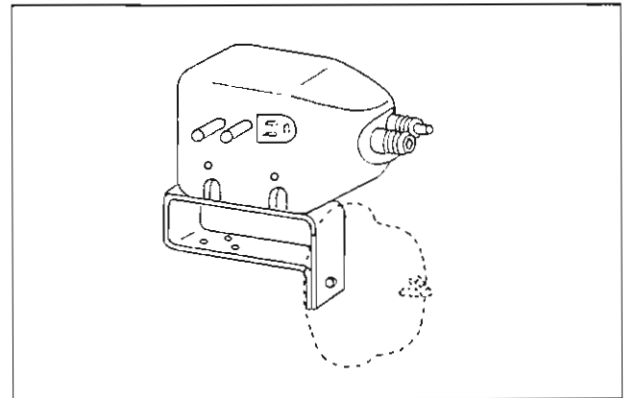

**STEP NO. 15** – Attach both new cables to regulator and tighten nuts. Check both cables to see that:

- A. Neither cable interferes with any hot or moving parts (servo, bead chain assembly, exhaust pipe, etc.).
- B. Cables are free of kinks and sharp bends (minimum six (6) inch radius for all bends).

**NOTE:** Speedometer cable must be installed behind bead chain and A/C hoses.

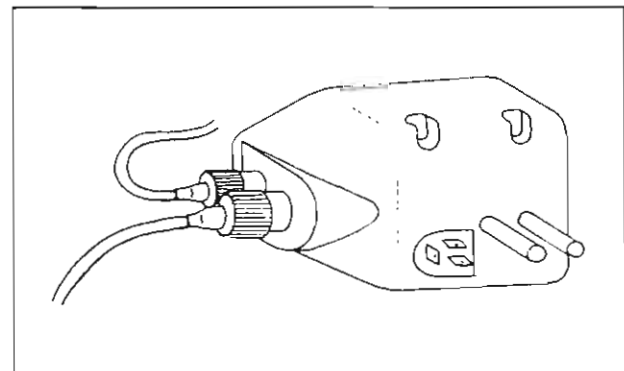

### ENGAGEMENT SWITCH MOUNTING

**STEP NO. 16** – Attach the engagement switch assembly (18) to turn signal lever with clamp provided and tighten set screw to hold in place.

**STEP NO. 17** – Remove lower half of plastic steering column shroud and route engagement switch harness inside shroud alongside steering column to under dash area. Replace steering column shroud.

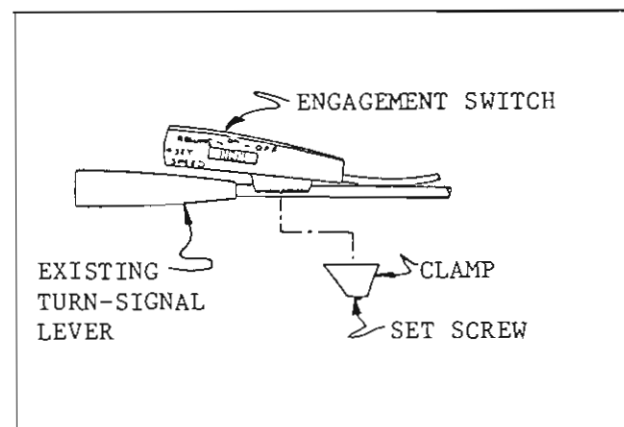

**STEP NO. 18** – Route wiring harness (17) from passenger compartment, through firewall into engine compartment and over to the right wheel well area for connection to regulator. Use existing grommet and hole located above speedometer cable grommet for this harness routing.

**STEP NO. 19** – Attach blue and white wires of wiring harness to vehicle brake light switch. The blue wire is connected to vehicle blue/red stripe wire and the white wire is connected to vehicle green wire. Use the self stripping connectors (15) to make these connections.

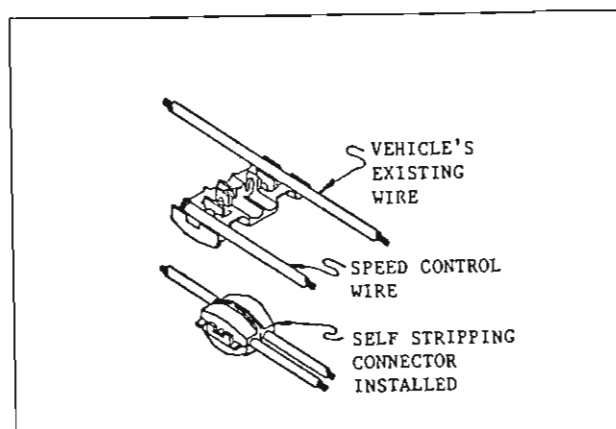

**STEP NO. 20** – Attach special female terminal on violet wire of wiring harness to #1 to #2 vehicle fuse terminal.

**STEP NO. 21** – Connect wiring harness to engagement switch harness (four-way connector red, brown, green and yellow wires).

**NOTE:** Relay of wiring harness may get hot during operation.

**STEP NO. 22** – Connect wiring harness to regulator. Plug the three wire connector onto the three terminals on back of regulator and the single connector (green wire) onto the threaded screw.

**STEP NO. 23** – Install grounding eyelet (black wire) under one of regulator mounting bolts and tighten both bolts securely.

## VACUUM TUBING GROUP

**STEP NO. 24** – Route and attach 9" length of vacuum tubing (23) from servo to "S" connector of regulator.

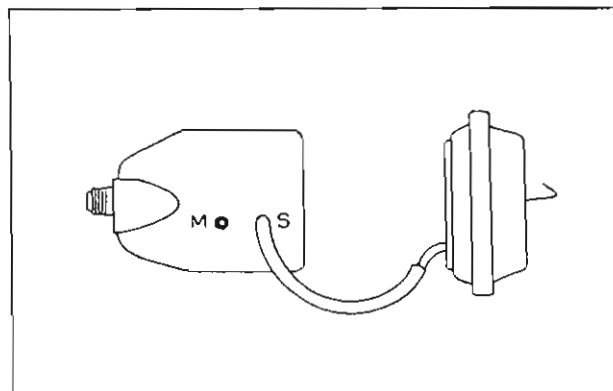

**STEP NO. 25** – Locate the 3/8" vacuum hose routed from the vacuum pump thru the firewall into the passenger compartment. Cut this hose approximately 6 inches from the firewall. Slip clamps (12) over hoses and insert 3/8 x 3/8 x 1/4 vacuum tee. (21) Attach remaining vacuum tube, with clamp to tee, route to regulator and attach to "M" connector.

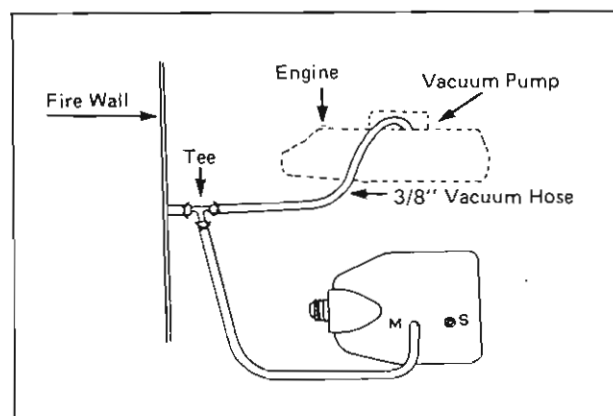

**STEP NO. 26** – The vacuum tubing and wiring harness may be tied together or out of the way with plastic straps (16) to prevent damage from moving parts, hot manifold, etc. Also, excess wiring harness may be tied up under the dash area.

**STEP NO. 27** – Install fuel canister in new position.

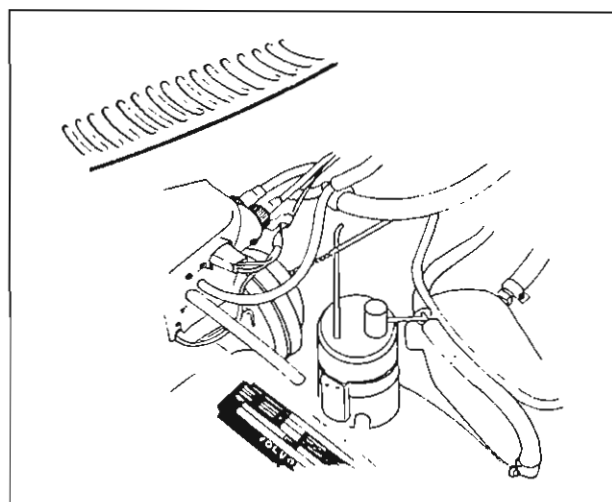

**STEP NO. 28** – Replace panel under steering wheel and reconnect battery cable.

# INSTALLATION IS NOW COMPLETE

# OPERATIONAL CHECK PROCEDURE

**CAUTION: CRUISE CONTROL SHOULD NOT BE ENGAGED ON WET OR SLICK ROADS.**

Perform the following checks after "Cruise Control" installation is completed. If problems are experienced during this operational check, refer to the Trouble Shooting Guide.

## IGNITION SWITCH OFF

**UNDER HOOD.** Manually operate vehicle's throttle linkage through its full travel, thus allowing the "Cruise Control" linkage (chain and cover) to go slack. Check to see that there is no possibility of the chain and cover becoming entangled with any adjacent parts (which would tend to hold the throttle open).

## TURN IGNITION SWITCH ON AND START ENGINE

1. Set emergency brake and put transmission in "park".
2. Move slide switch to "on" position.
3. Depress set speed button and hold for approximately 2 seconds. System should NOT engage. If system **DOES** engage, (engine races), immediately turn ignition off, and check all connections for proper adjustment.
4. Start Engine. Disconnect vacuum hose at regulator from the "M" connector. Engine speed

should increase somewhat and idle will be rougher. There should be vacuum available at the hose end. If not reconnect vacuum hose and check all connections for leakage.

## VEHICLE ROAD CHECK

(Should be made on open or uncongested highway.)

1. Move slide switch to "ON" position.
2. Drive at 10 miles per hour, depress and release set speed button. The system should not engage. (Normally system should engage at speeds above 30 mph.)
3. Drive at 45 miles per hour. Depress the set speed button and release. System should engage and hold within plus or minus 2 mph.
4. Depress brake pedal. System will disengage.
5. Move slide switch to "Resume" position and release. Vehicle will resume pre-set speed.
6. Move slide switch to "OFF" position. System will be completely disengaged.

## ELECTRICAL CHECKS

It is not always necessary to remove the regulator in case of inoperative Cruise Control. The following checks should be performed as part of the diagnosis to determine the cause and correction of Cruise Control trouble:

1. Disconnect push on connectors at regulator (single and triple). Grounding lug may be left connected.
2. Turn ignition switch to accessory position.
3. Move slide switch to the "On" position.
4. Using a test light, ground one test light lead and touch the other lead to the brown wire and then the green wire at the connectors. Test light should light. If test light does not light on brown wire, check fuse, engagement switch, and newly made connection at power source. If test light does not light on green wire, check engagement switch and newly made connections at power source and brake light switch.
5. Push "set speed" button all the way in and hold. Ground one test light lead and touch the other lead to each wire in the connector. Test light should light on the brown and yellow wires and should not light on the green or blue wire.
6. Release "set speed" switch button.
7. Move slide switch to "resume" position and hold. Ground one test lamp lead and touch the other lead to each wire in the connector. Test bulb should light on all wires except the blue wire (blue connects to brake lamp side of the brake light switch).

To make an independent check of the engagement switch before removal from the vehicle, disconnect the switch from the wiring harness, at the multiple connector (see Diagram Page 4) in the passenger compartment, and make the following checks: (Omit steps 8 thru 15 if step 1 thru 7 check out.)

8. Attach a jumper wire from a 12-volt power source to the red lead of the engagement switch.
9. Move slide switch to the "off" position.
10. Using the test light, ground one test light lead and touch the other lead, in turn, to the brown wire, the green wire and the yellow wire. The test light should not light on any of these wires.
11. Move slide switch to "on" position.
12. Touch test light lead to the brown wire and then the green wire. The test light should light on each of these. Touch the lead to the yellow wire. Light should not light.
13. Push "set speed" all the way in and hold. Test light should light on the brown wire and on the yellow wire. Test light should not light on the green wire.
14. Release "set speed" switch button.
15. Move slide switch to "resume" position and hold. Touch the test light lead in turn, to the brown wire, the yellow wire and then to the green wire. Test light should light.

**NOTE:** If Steps 1 thru 7 do not check out and Steps 8 thru 15 do check out, replace wiring harness. If steps 8 thru 15 do not check out, replace the engagement switch.

## BRAKE RELEASE CHECK

1. Disconnect multiple connector from regulator (all other connections are made).
2. Touch one test light lead to blue wire and other test light lead to ground. Bulb should not light.
3. Depress brake pedal; test light and brake lights should go on when pedal is depressed and off when pedal is released.

**NOTE:** Excessive brake pedal travel necessary to activate test light may result in vehicle braking before release of Cruise Control System. If this is objectionable adjust brake light switch.

4. If above sequence fails – check for brake light switch adjustment, defective switch, or defective brake light circuit fuse.

## REGULATOR SPEED ADJUSTMENT

If vehicle accelerates or decelerates more than 2 mph upon operating set speed button, a regulator speed adjustment may be necessary.

**CAUTION:** This should be accomplished by *EXTREMELY fine adjustments*.

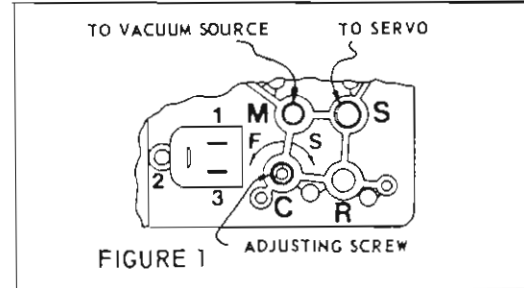

1. If vehicle accelerates more than 2 mph after depressing set speed button, turn speed adjusting screw "C" *slightly* toward S.
2. If vehicle decelerates more than 2 mph after depressing set speed button, turn speed adjusting screw "C" *slightly* toward F.

## VACUUM CHECK

Make sure vacuum hoses are properly connected and carefully routed.

**WARNING:** If hose connected to servo is collapsed or kinked, servo may keep throttle open even though brake is applied.

## CIRCUIT DIAGRAM

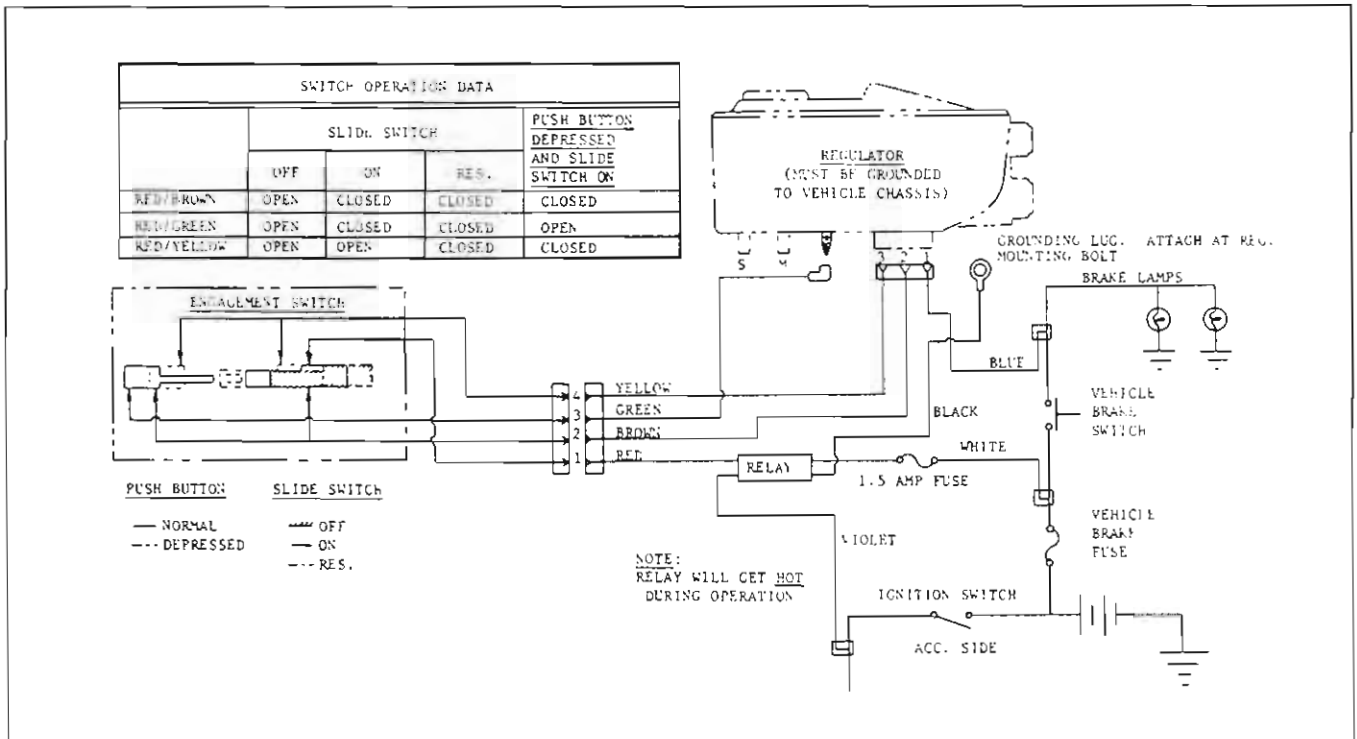

# TROUBLE SHOOTING GUIDE

## DESCRIPTION

The regulator is driven by a flexible drive cable from the transmission. The speedometer is driven by another flexible drive cable from the regulator. The engagement switch electrically controls the regulator which in turn controls the vacuum from the intake manifold to the servo which

actuates the throttle. Electrical connections are provided for attachment to the existing brake light switch to cause disengagement of the unit when brakes are applied. For your convenience and safety the slide switch will disengage the entire system when pushed to the "off" position.

CONDITION	POSSIBLE CAUSE	REMEDY
Blowing fuses	Short or ground in Cruise Control wiring circuit	Perform electrical checks Replace only with 1.5 amp fuse
Cruise Control does not engage	Cruise Control harness fuse burnt out	Replace fuse (1.5 amp only)
	Brake light switch on	Adjust or replace brake light switch
	Faulty brake light switch	Replace brake light switch
	No current to brown wire	Repair wiring harness or check for loose connection
	Vacuum leak	Repair leak
	Bad ground	Check regulator for ground
	Electrical	See electrical check
	No ground	Add wire from regulator to ground
	Faulty connections	Tighten connections
	Brake light fuse burnt out	Replace fuse
	Brake lamp bulb burnt out	Replace bulb
	Engaging switch inoperative	Replace engaging switch — See electrical checks — Steps 8 thru 15

Cruise Control does not disengage when brake is applied	Improper brake light switch adjustment	Adjust brake light switch
	Defective brake light switch	Replace brake light switch
	Collapsed tube from Servo to regulator	Replace tube
Re-engages when brake is released	Faulty engagement switch	Replace engagement switch
Vehicle's battery discharged	Improper wire connections	Select correct power source — See Installation Instructions
Vehicle's battery discharged & Cruise Control switch left "on"	Defective relay in Cruise Control wiring harness	Replace wiring harness — Important: Replace Cruise Control fuse only with a 1.5 amp fuse
Engine does not return to normal idle	Improper Cruise Control Servo linkage adjustment	Adjust Cruise Control servo linkage
	Improper accelerator linkage adjustment	Adjust accelerator linkage
	Weak or disconnected throttle return spring	Replace or connect spring
Pulsating accelerator pedal	Speedometer cable or drive cable kinked or lack of lubrication	Lubricate cables lightly, including tips, or replace cable if necessary
Speedometer inoperative & Cruise Control operates	Speedometer cable not driving speedometer	Check for broken cable or loose connections
	Faulty regulator	Replace Regulator
Neither speedometer nor Cruise Control operates	Transmission cable not driving regulator	Check for broken cable or loose connections
	Faulty regulator	Replace Regulator
Vehicle accelerates or decelerates more than 2 MPH upon depressing of engagement switch	Regulator out of adjustment	Refer to Regular Speed Adjustment, page 18
Engine accelerates when started	Vacuum tubes reversed at regulator	Check instructions sheet for proper connections
System disengages on level road without applying brake	Loose wiring connections or poor ground	Tighten connections and check ground
	Loose tubes	Check tube connections
	Servo linkage chain broken or throttle clamp slipped	Repair chain or tighten clamp
Erratic operation of Cruise Control	Faulty vacuum servo or vacuum tube	Replace servo or vacuum tube
	Faulty regulator	Replace regulator

